

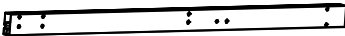

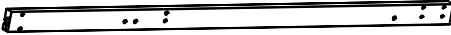







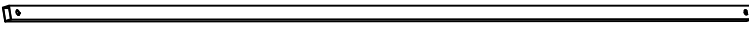
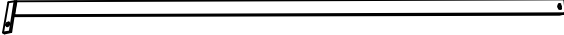

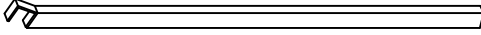
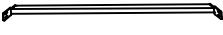





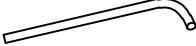









NO.	PARTS	QTY
A		4pcs
B		2pcs
C		2pcs
D		2pcs
E		2pcs
F		4pcs
G		8pcs
H		1pc
K		8pcs
P		4pcs

NO.	PARTS	QTY	NO.	PARTS	QTY
N		4pcs	14		4pcs
O		4pcs	15		96pcs
3		4pcs	16		16pcs
4		1pc	17		1pc
5		2pcs	18		1pc
6		4pcs	19		148pcs
7		4pcs	20		20pcs
8		4pcs	21		4pcs
10		4pcs	X1	 M6*15	112pcs
11		4pcs	X2	 M6*40	16pcs
12		1pc	X3	 M6*30	20pcs
13		4pcs			

STEP 1

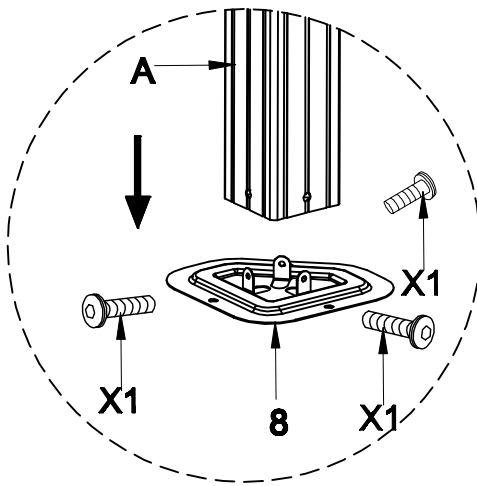
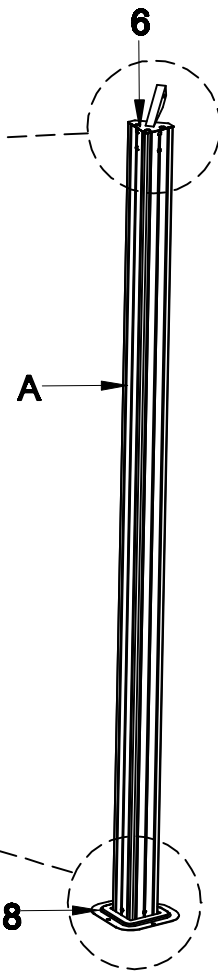
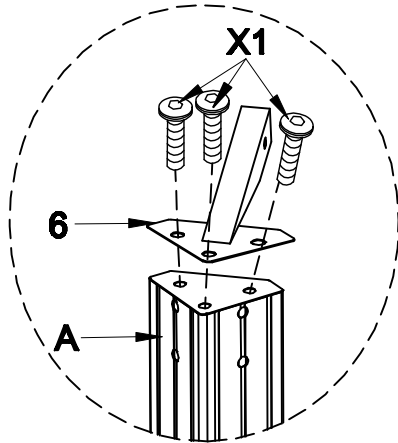
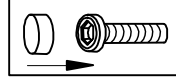

STEP 2

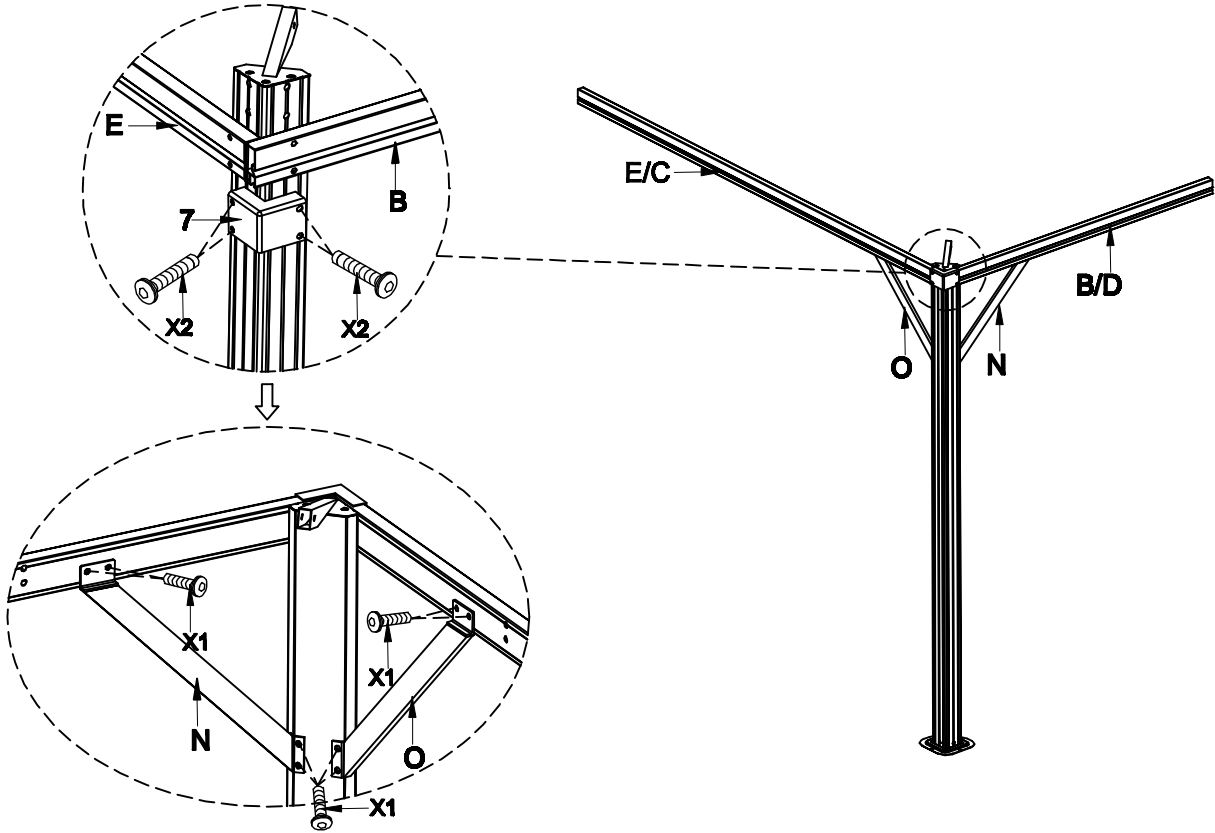
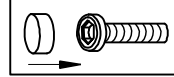

STEP 3

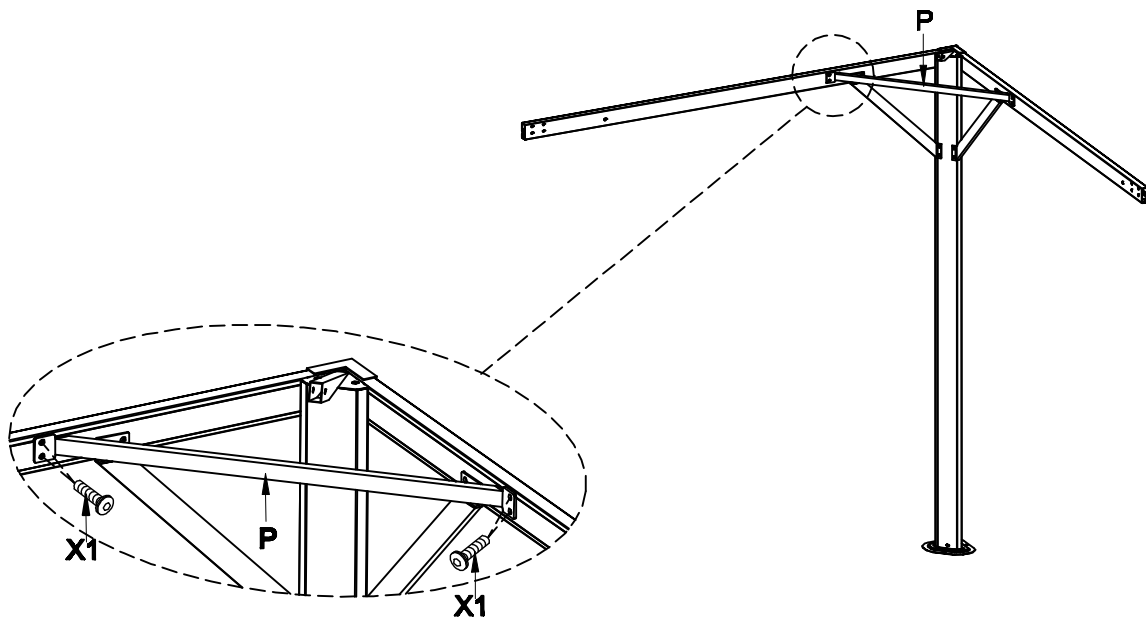
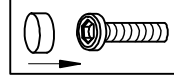

STEP 4

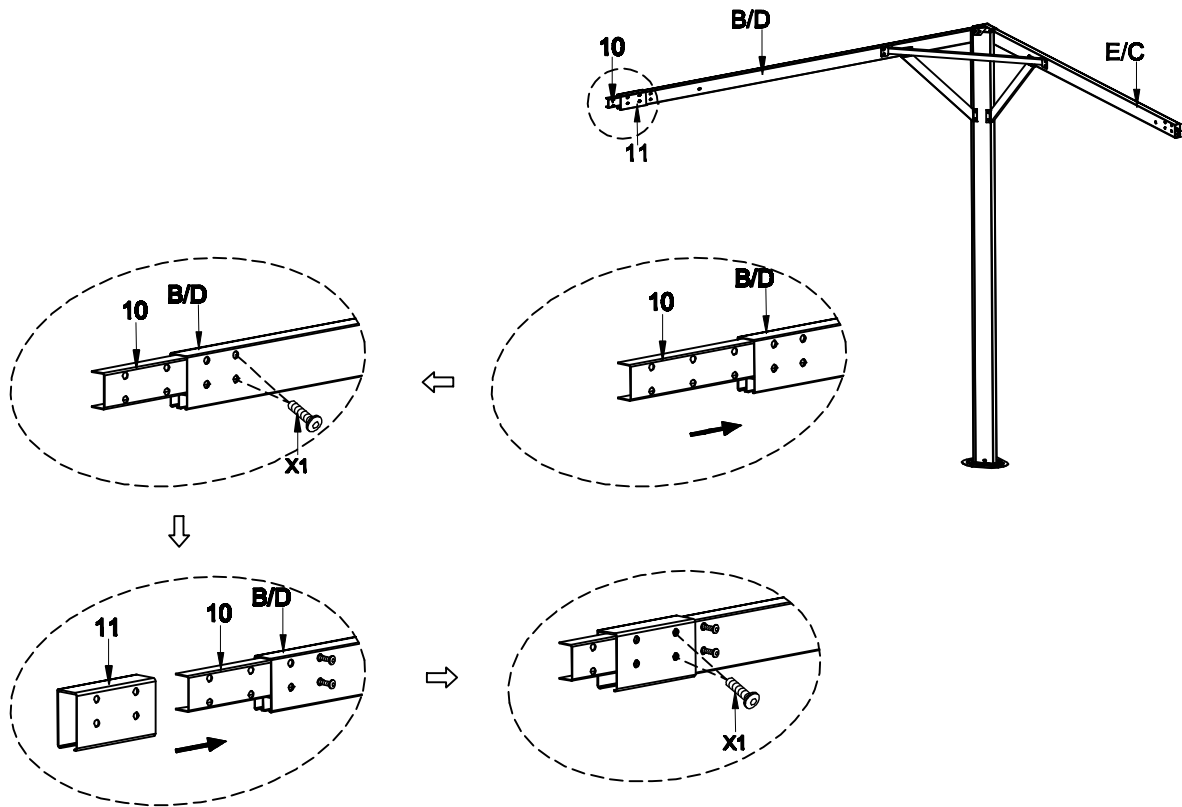
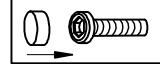

STEP 5

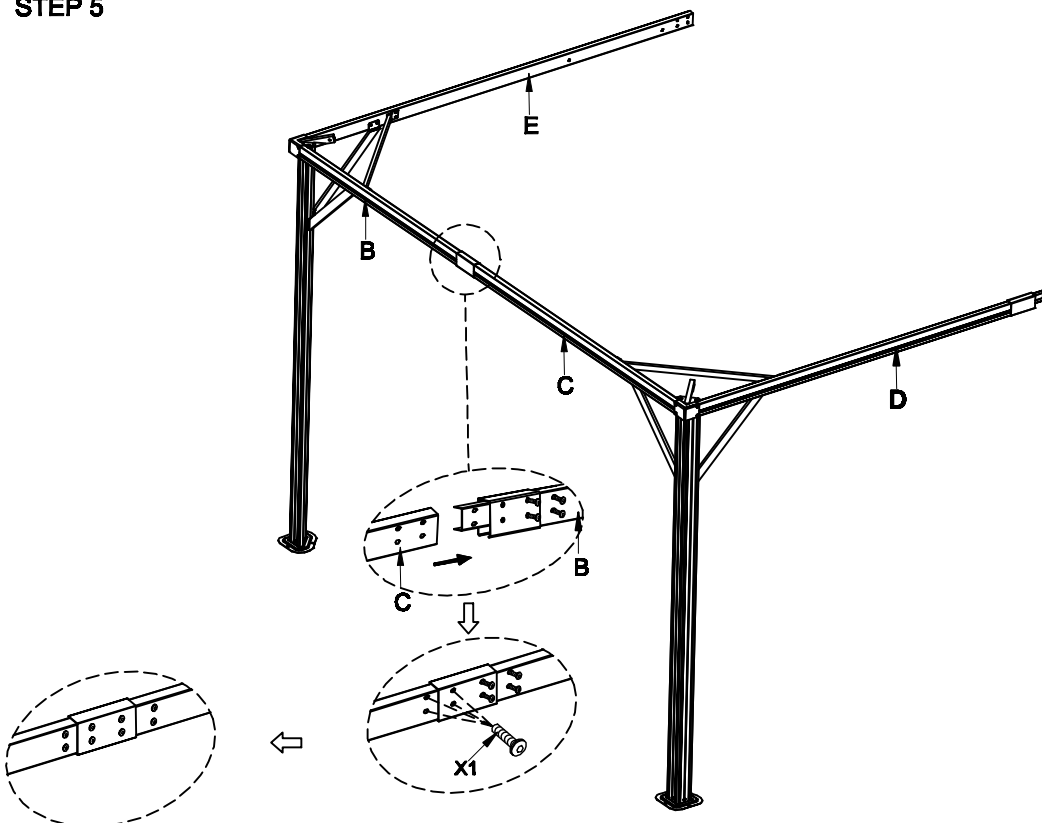
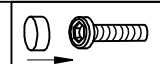

STEP 6

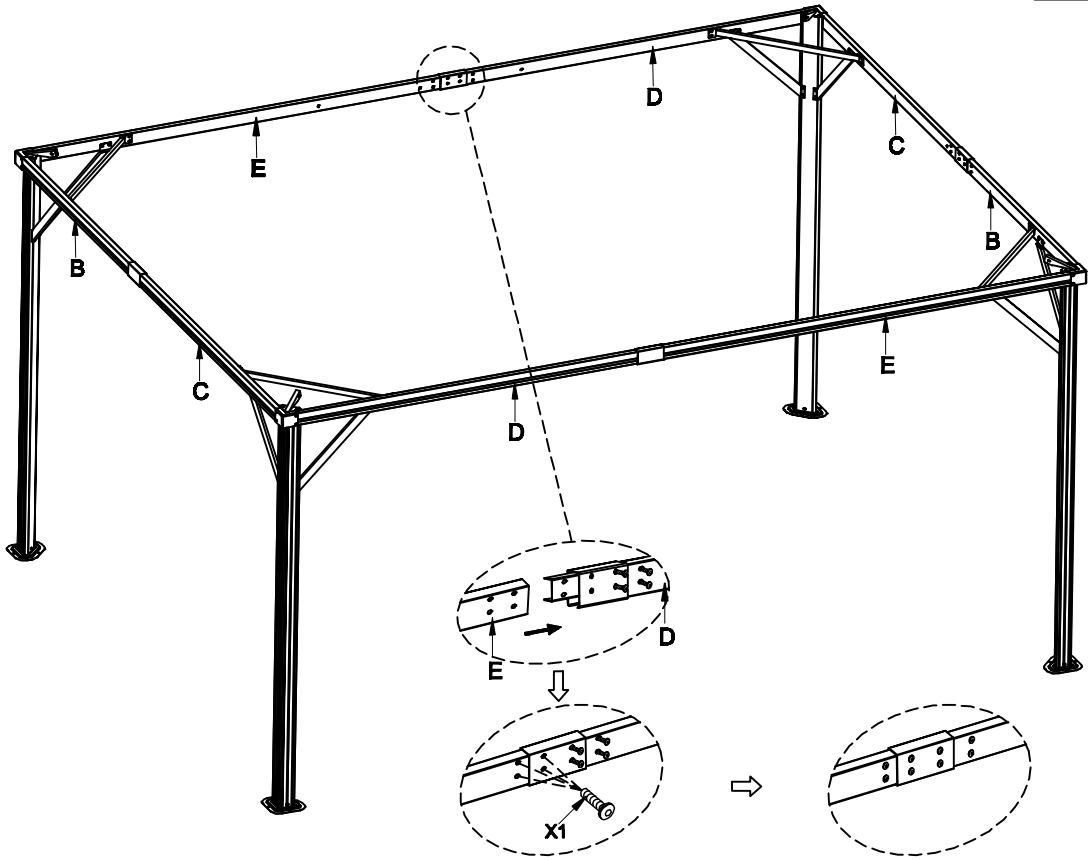
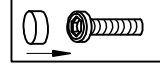

STEP 7

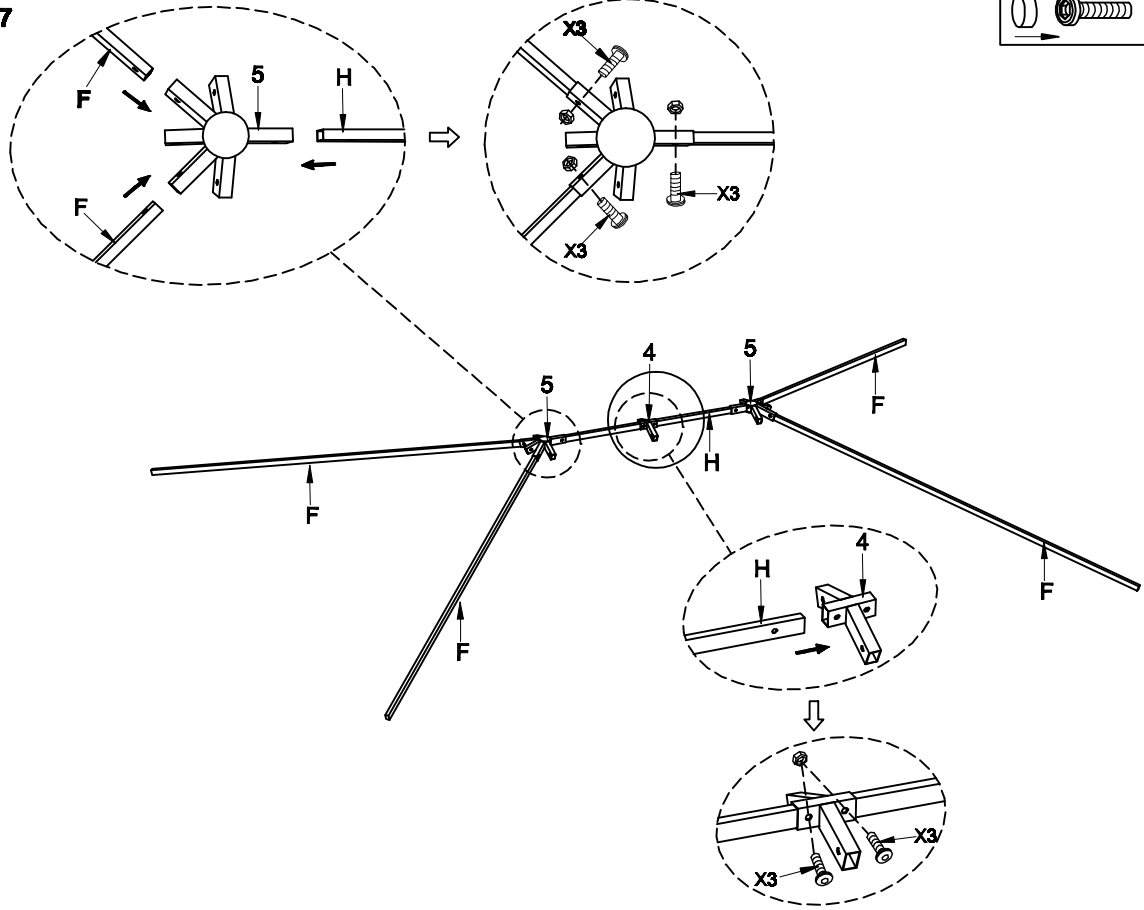
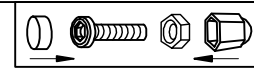

STEP 8

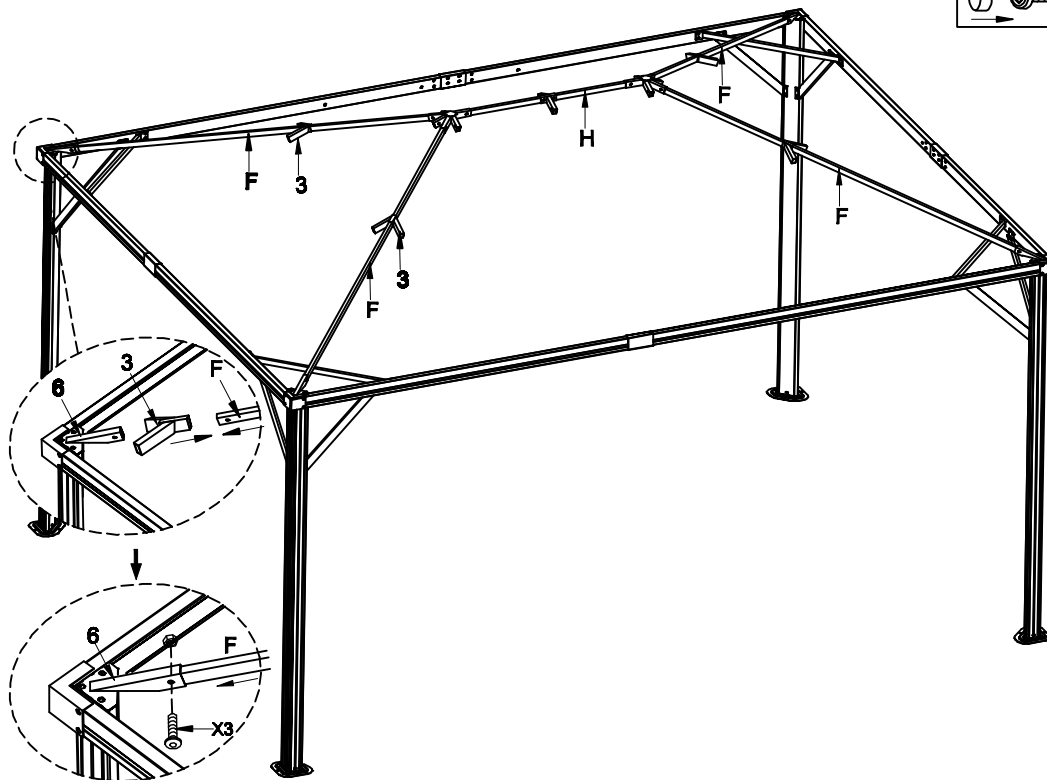
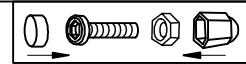

STEP 9

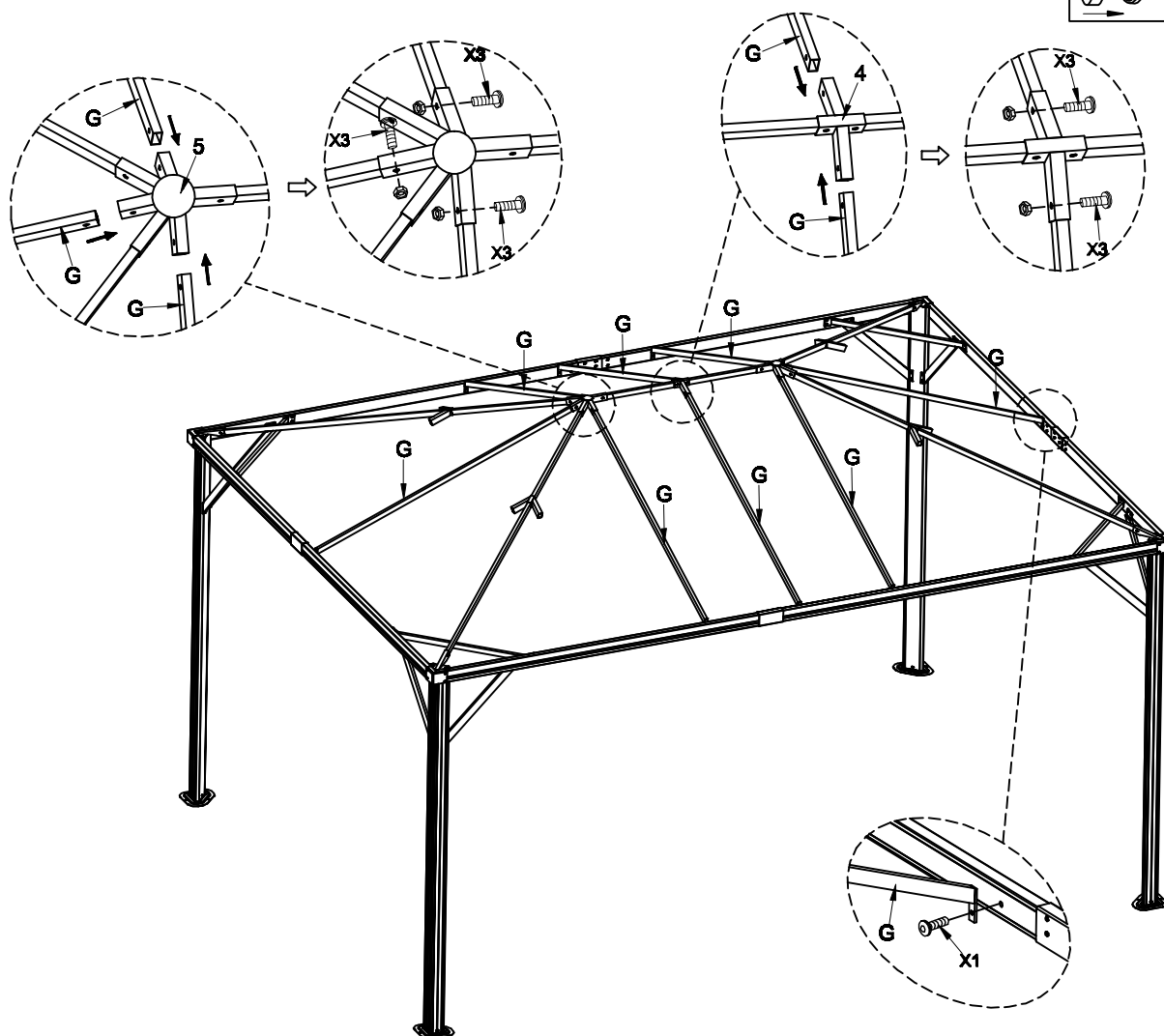
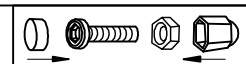

STEP 10

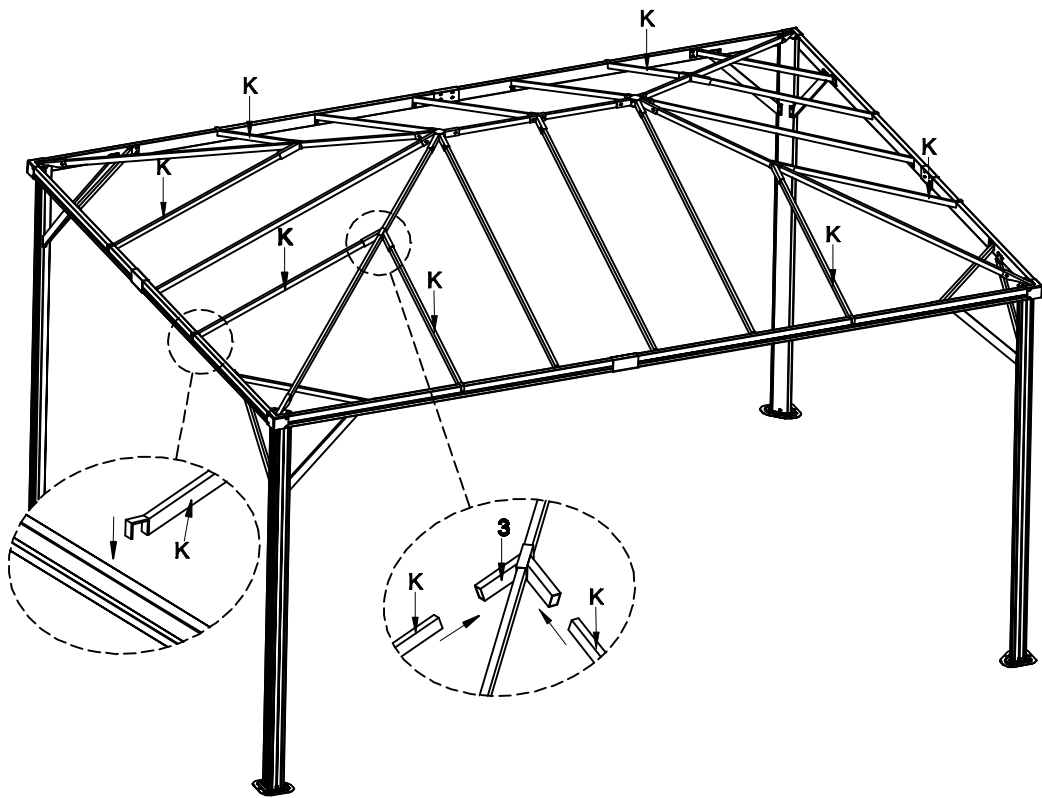

STEP 11

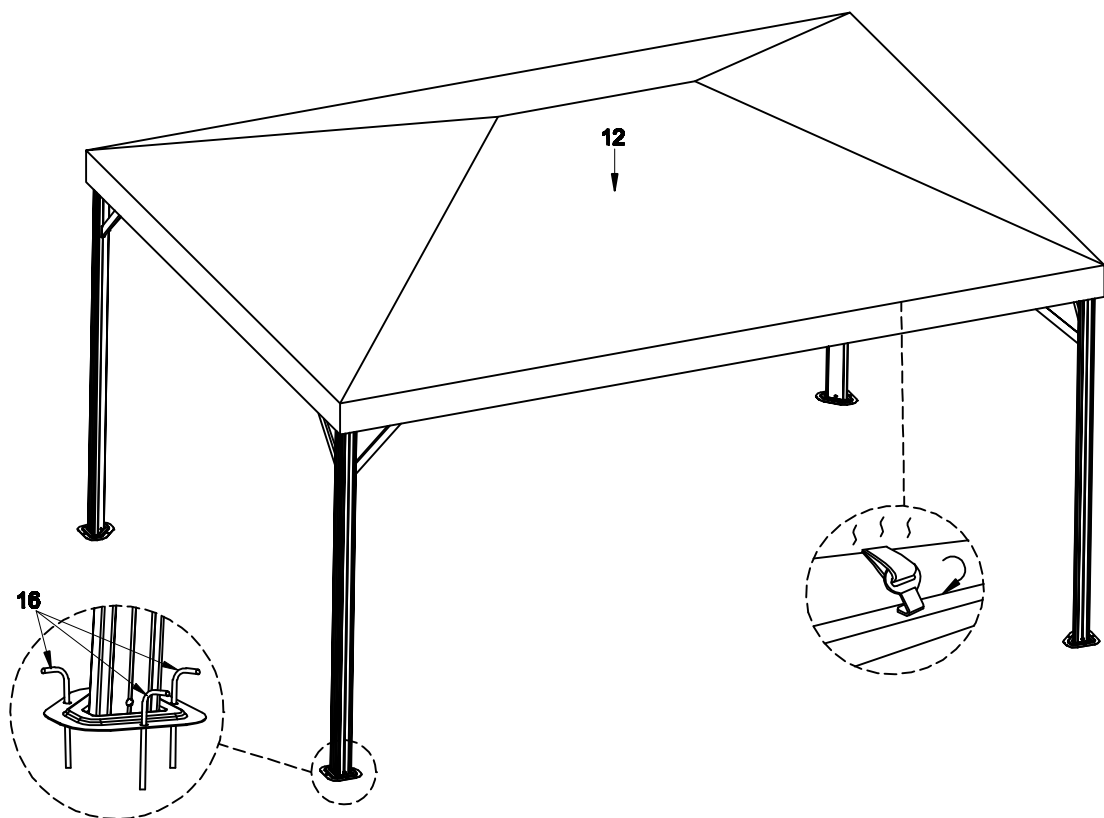

STEP 12

